

No. of Contacts	DIMENSIONS		REMARK (備註)
	A	B	
4	2.54	5.58	○
6	5.08	8.12	○
8	7.62	10.66	○
10	10.16	13.20	○
12	12.70	15.74	○
14	15.24	18.28	○
16	17.78	20.82	○
18	20.32	23.36	○
20	22.86	25.90	○
22	25.40	28.44	○
24	27.94	30.98	○
26	30.48	33.52	○
28	33.02	36.06	○
30	35.56	38.60	○
32	38.10	41.14	○
34	40.64	43.68	○
36	43.18	46.22	○
38	45.72	48.76	○
40	48.26	51.30	○
42	50.80	53.84	○
44	53.34	56.38	○
46	55.88	58.92	○
48	58.42	61.46	○
50	60.96	64.00	○
52	63.50	66.54	○
54	66.04	69.08	○
56	68.58	71.62	○
58	71.12	74.16	○
60	73.66	76.70	○
62	76.20	79.24	○
64	78.74	81.78	○
66	81.28	84.32	
68	83.82	86.86	
70	86.36	89.40	
72	88.90	91.94	
74	91.44	94.48	
76	93.98	97.02	
78	96.52	99.56	
80	99.06	102.10	

PHGZ-XXS-X-032

Number of Contacts Straight Contact Plating

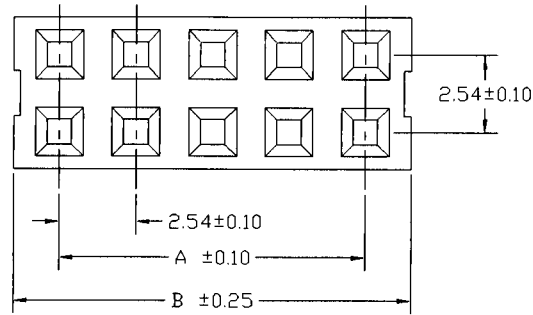

Definition	Code	
◎ Tin plated:	A	
◎ Gold plated:		
flash	B	15μ" F
10μ"	E	30μ" J
◎ Duplex plating:		
flash	K	15μ" P
10μ"	N	30μ" U
◎ Standard:	B	

SPECIFICATIONS

Current Rating: 3 Amps
 Insulator resistance: 5000 Megohms Min.
 Contact resistance: 20 m ohm Max.
 Dielectric withstanding: AC 500 V
 Operating Temperature: -40° - +105°C
 Contact Material: Phospher bronze
 Insulator Material: Polyester, UL 94V-0
 ◎ Standard: P.B.T

Finish: Tin, Gold or Duplex plated

◎ Note:

Duplex plating: gold plated on contact area,
 Tin on solder area

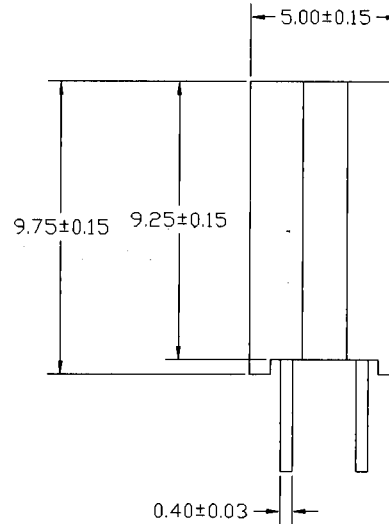
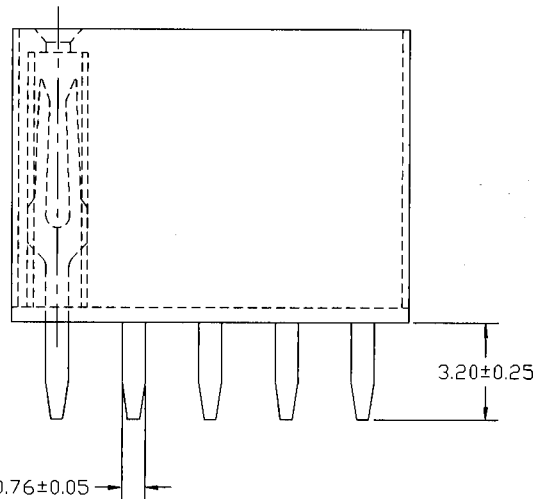

Recommended P.C.Board Hole Layout

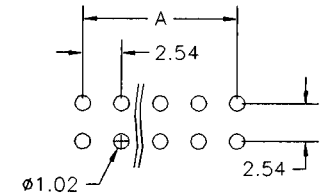

△ PHG2-XXS-XXX-3.2	VERSION	PHGZ-XXS-X-032	15-10-02'
--------------------	---------	----------------	-----------

標準規格



GENERAL TOLERANCE	
XX. ±	XXX. ±
X. ±	.XXX ±
.X ±	.X' ±
.XX ±	.X" ±

SCALE	4=1
UNIT	MM
SIZE	A4

DRAWN	邱若瑋	DATE	15-10-02'
CHECK	陳銀中	DATE	16-10-02'
APPROVE	陳俊任	DATE	17-10-02'

DWG. NO.	F:\DWG\CDWG\PHG\PHGZSOA.DWG
PARTS NO.	PHGZ-XXS-X-032 △

TITLE	成品規格圖
-------	-------

REV.	1.1
SHEET	1/2